

# SK SERIES DIGITAL SCALE



## FEATURES

- 1/2,000 Resolution
- Solid and Reliable Design
- Splash-Proof (Drip Tight)
- Large and Clear LCD Display (25mm)
- Large, Rectangular Weighing Pan
- Portable (6 x "D" Size Batteries)
- Net Weight and Stability Indicator
- Low Battery Indication
- Separate Keys for Power and Re-Zero
- Auto Power Off Feature
- AC Adaptor (Optional)

## MODELS

MODEL	CAPACITY & DIVISIONS
SK-1000	1,000g x 0.5g
SK-2000	2,000g x 1g
SK-5000	5,000g x 2g
<b>SK-5001</b>	<b>5,000g x 1g</b>
SK-10K	10kg x 5g
SK-20K	20kg x 10g
SK-30K	30kg x 20g

## DIMENSIONS

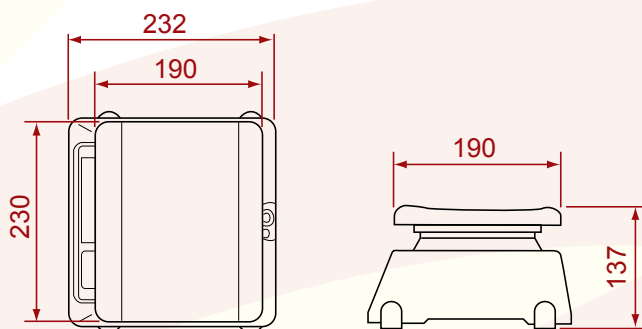

TOP VIEW

SIDE VIEW

## SPECIFICATIONS

MODEL	SK-1000	SK-2000	SK-5000	SK-5001	SK-10K	SK-20K	SK-30K
Capacity/Divisions	1,000 x 0.5g	2,000 x 1g	5,000 x 2g	5,000 x 1g	10kg x 5g	20kg x 10g	30kg x 20g
Linearity	±1g	±2g	±5g	±2g	±10g	±20g	±50g
Repeatability	0.5g	1g	2g	1g	5g	10g	20g
Display	Liquid Crystal Display, 25mm High Digits						
Pan Size	230mm (W) x 190mm (D)						
Battery Life Approx.	600 hours with manganese type batteries 1200 hours with alkaline type batteries						
Operating Temp.	-10°C to +40°C						
Weight	1.6kg					1.9kg	
Calibration Mass	1,000g	2,000g	5,000g	5,000g	10kg	20kg	30kg
Power	6 x "D" size batteries or AC adaptor (optional)						