

GB SERIES GROSS BAGGER



DESCRIPTION

Accuweigh's proven range of Gross Baggers are suitable for bagging most types of products including dry, granular, lumpy, crushed or powdered products into bags up to 50kg.

Gravity, Screw, Vibratory or Conveyor Fed, the GB50 is based on digital weighing technology and pneumatic control. Over many installations, the design has proven to be both reliable and accurate.

The GB50 utilises the well proven "weigh in bag" method that has been perfected over many decades. The bag spout is fully suspended on precision loadcells and the dedicated weight controller ensures that accuracy is achieved using automatic free fall compensation and two stage fill.

On-screen reporting of bag count and total weight packed is useful information for Production and Quality Managers.

FEATURES

- Fully Electronic Loadcell Weighing System
- Fills up to 10 Bags per Minute
- Bag Weights up to 50kg
- In-flight Compensation
- RS-232C / RS-422 / RS-485 Communications
- Maximum 99 Preset Product Memories
- Totalised Bag Count and Weight for Each Memory
- Tolerance Check
- Two-Stage Filling
- Simple Operation and Maintenance
- Fully Stainless Steel Model Available
- Designed and Manufactured in Australia

Designed and
Manufactured by
budpak
PACKAGING SYSTEMS



DIGITAL INDICATOR



Shown with Optional Pedestal and Feed Hopper

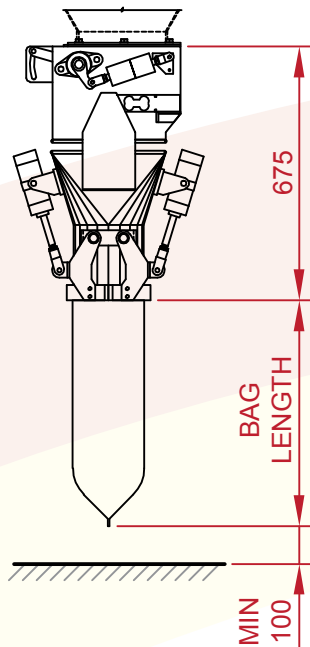

SYSTEM OVERALL DIMENSIONS

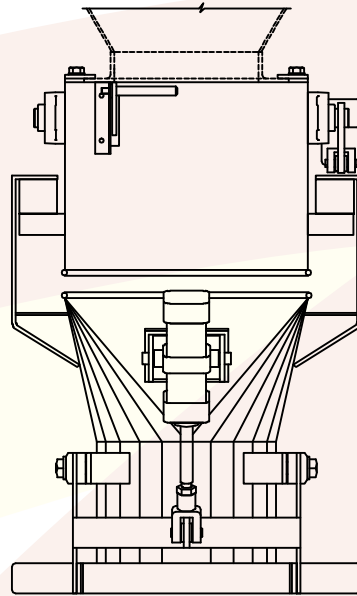

GB50 SIDE VIEW

OPTIONS

- Printers and Statistical Software
- Sewing Machines and Heat Sealers
- Bag Closing Conveyors
- Scissor Lift Table
- Turnkey Packaging

ACCURACY

Consistent, repeatable accuracy is achieved because the Gross Bagger has a dual-stage filling system. The majority of the product is filled at the maximum fill rate. Just prior to attaining the target weight, the fill rate is reduced to a “dribble” feed to allow the system to more accurately halt product flow to achieve the desired target weight.

THE COMPLETE BAGGING LINE

From product supply to Bag Closing, Palletising and Stretch Wrapping, **Accuweigh** supplies the complete range of equipment to suit your product and throughput.

- 1 GB SERIES GROSS BAGGER (PEDESTAL-MOUNTED UNIT SHOWN)
- 2 NEWLONG AUTOMATIC SEWING MACHINE WITH IN-FEED DEVICE
- 3 BAG CLOSING CONVEYOR

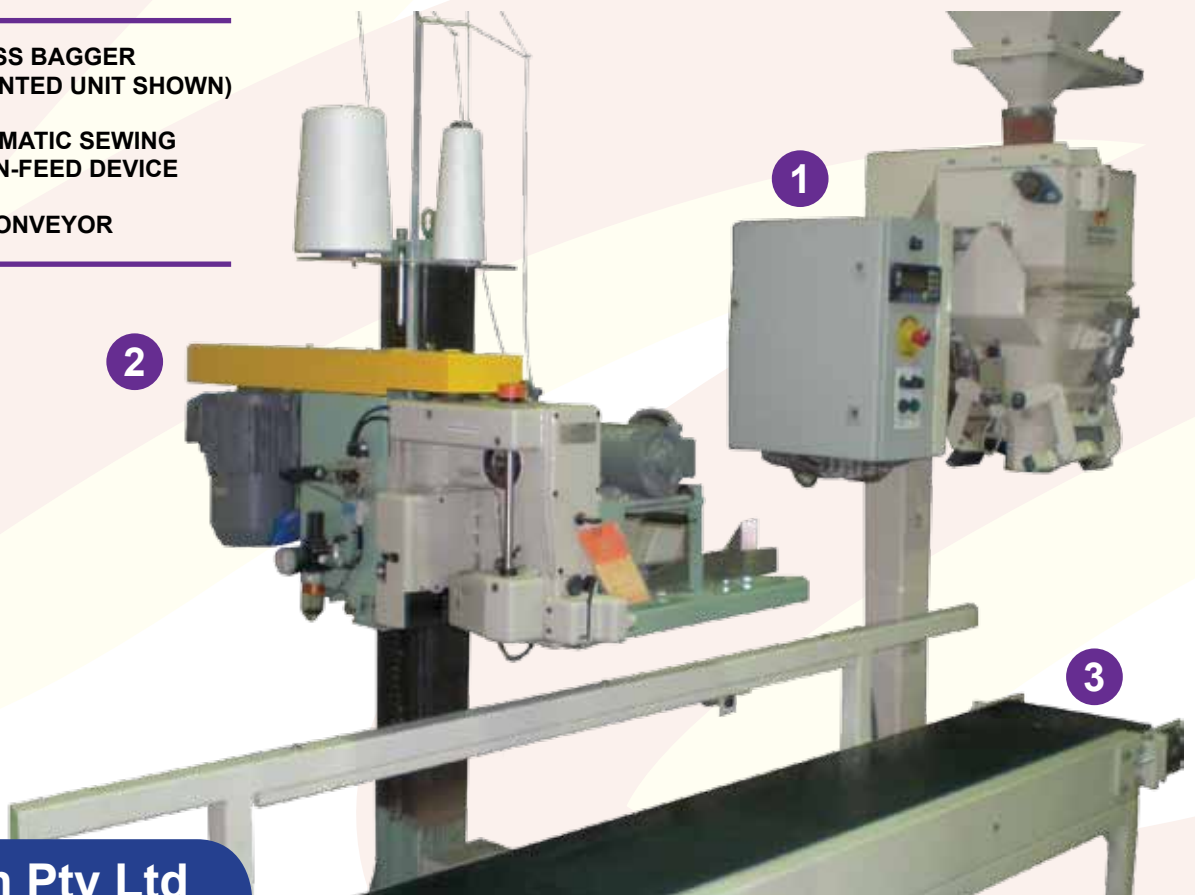

Accuweigh Pty Ltd

BROCHURE: AW128 | REVISION: F12

WESTERN AUSTRALIA (HEAD OFFICE):
PHONE: (08) 9259 5535

SOUTH AUSTRALIA OFFICE:
PHONE: (08) 8447 5011

NEW SOUTH WALES (SYDNEY) OFFICE:
PHONE: (02) 9728 4877



www.accuweigh.com.au

VICTORIA OFFICE:
PHONE: (03) 9548 5554

NEW SOUTH WALES (NEWCASTLE) OFFICE:
PHONE: (02) 4966 8900

QUEENSLAND OFFICE:
PHONE: (07) 3265 5520